

INTERFACE CONTROL DOCUMENT

REVISIONS				
ZONE	REV.	DESCRIPTION	DATE	APPROVED
	D1	INITIAL RELEASE	2/02/2012	EMH
	A	CHANGED DISPLAY STATES OF ALL VIEWS TO WIRE FRAME. UPDATED NOTE FOR LEMO CONNECTOR. ADDED MISSING DIMENSIONS.	9/6/2012	B. MOAK
	B	NEW GENERATION OF NX CAMERAS. SIDE COVERS AND CENTER TUBE CHANGED. NOT OVERALL DIMENSIONS.	9/20/2012	B. MOAK

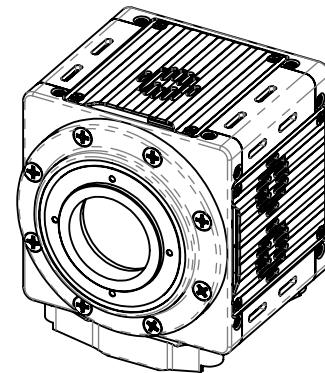
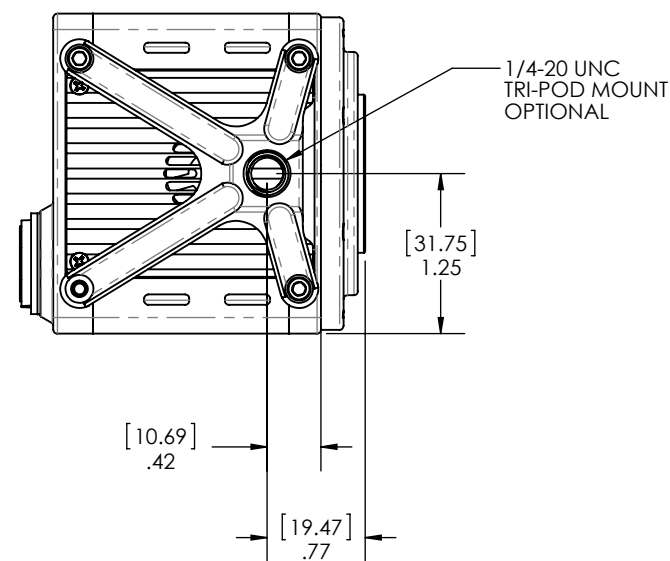
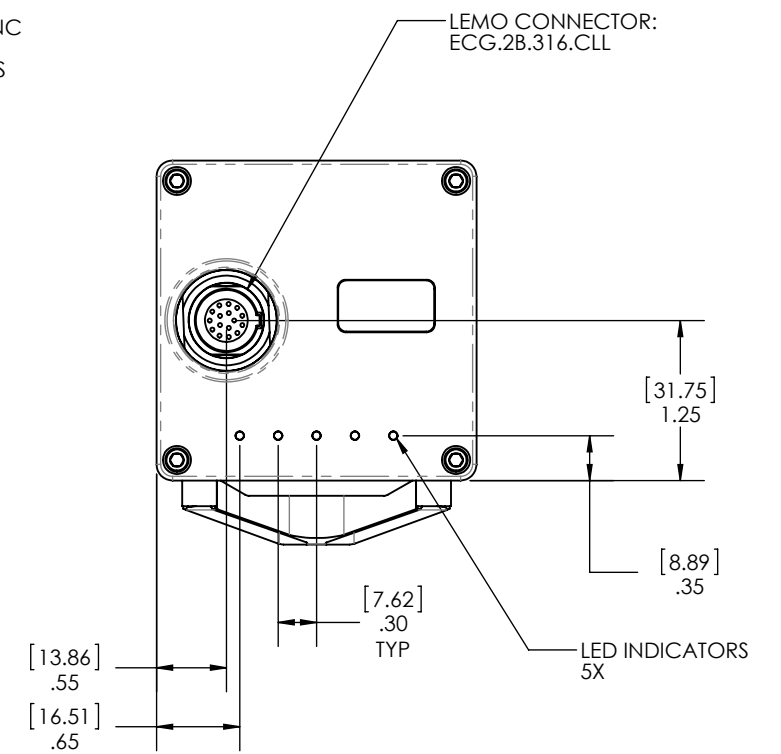
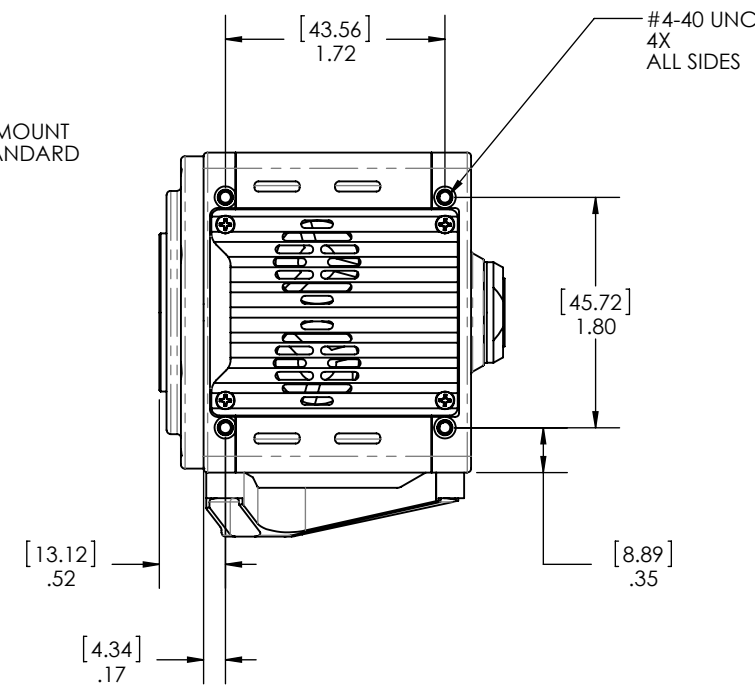
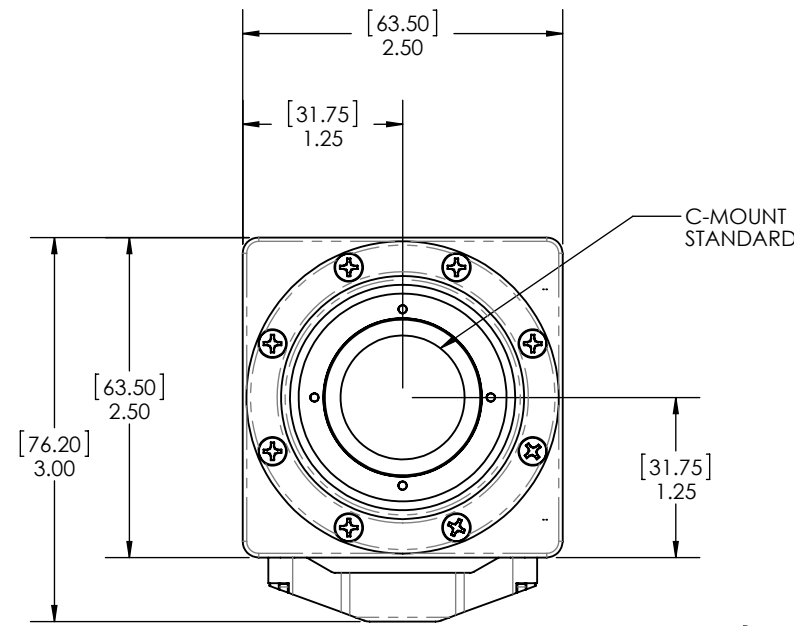
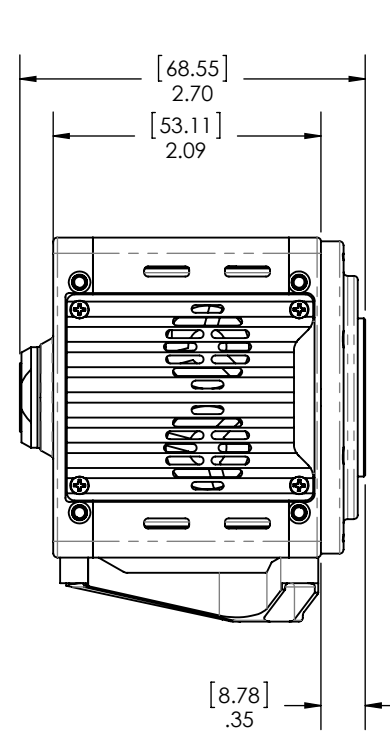
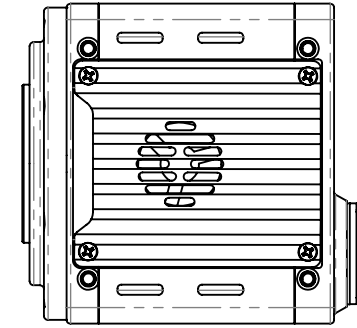
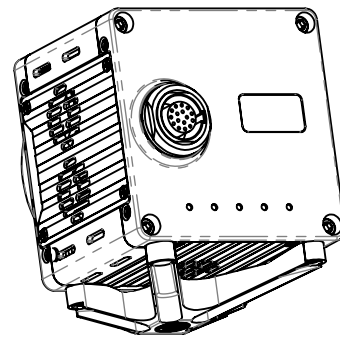

THIRD ANGLE PROJECTION	NEXT ASSY	USED ON
	APPLICATION	

PROPRIETARY AND CONFIDENTIAL
THE INFORMATION CONTAINED IN THIS DRAWING IS THE SOLE PROPERTY OF INTEGRATED DESIGN TOOLS INC. ANY REPRODUCTION IN PART OR AS A WHOLE WITHOUT THE WRITTEN PERMISSION OF INTEGRATED DESIGN TOOLS INC. IS PROHIBITED.

INTERPRET THIS DRAWING PER ASME Y14.5M-1994
 UNLESS OTHERWISE SPECIFIED: DIMENSIONS ARE IN INCHES
 TOLERANCES ON:
 FRACTIONAL DECIMAL ANGULAR
 ± 1/16 .X ± .1 ± 1°
 .XX ± .03
 .XXX ± .010

PROJECT NAME:	DATE:
BRYAN MOAK	2/12/2012
ERIC HEININGER	2/12/2012
LUIZ LOURENCO	2/12/2012

INTEGRATED DESIGN TOOLS, INC 1 WEST MOUNTAIN STREET SUITE 3 PASADENA, CA 91103		
TITLE: INTERFACE CONTROL DOCUMENT, NX CAMERA		
SIZE: B	DWG. NO. 1084-0900 ICD	REV B
SCALE: 2:3	DATE: 9/20/2012	SHEET 1 OF 1